

MODERNE 5

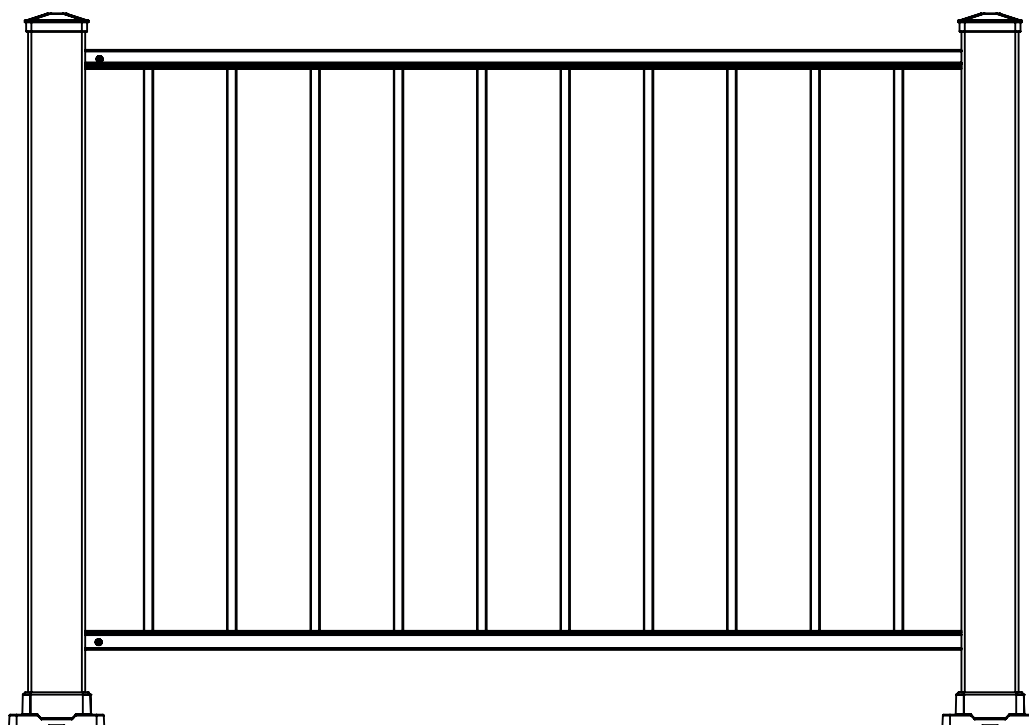

***POTEAU VENDU SÉPARÉMENT**

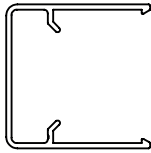

X 2
MOULURE DE FINITION

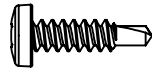

X 16
VIS

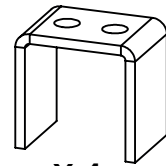

X 4
CRAN

ÉTAPE 1

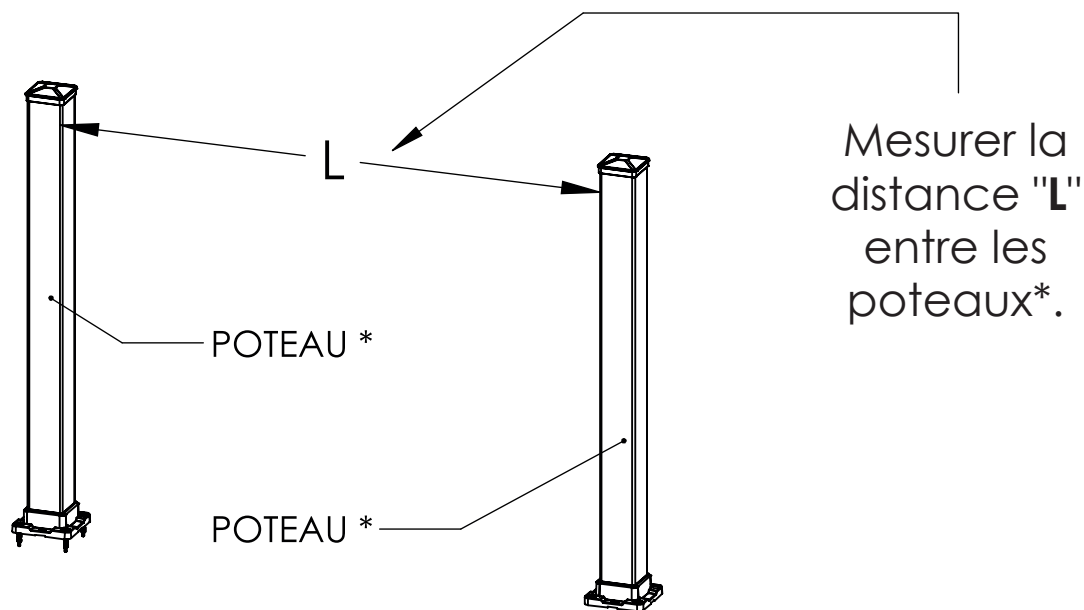

ÉTAPE 2

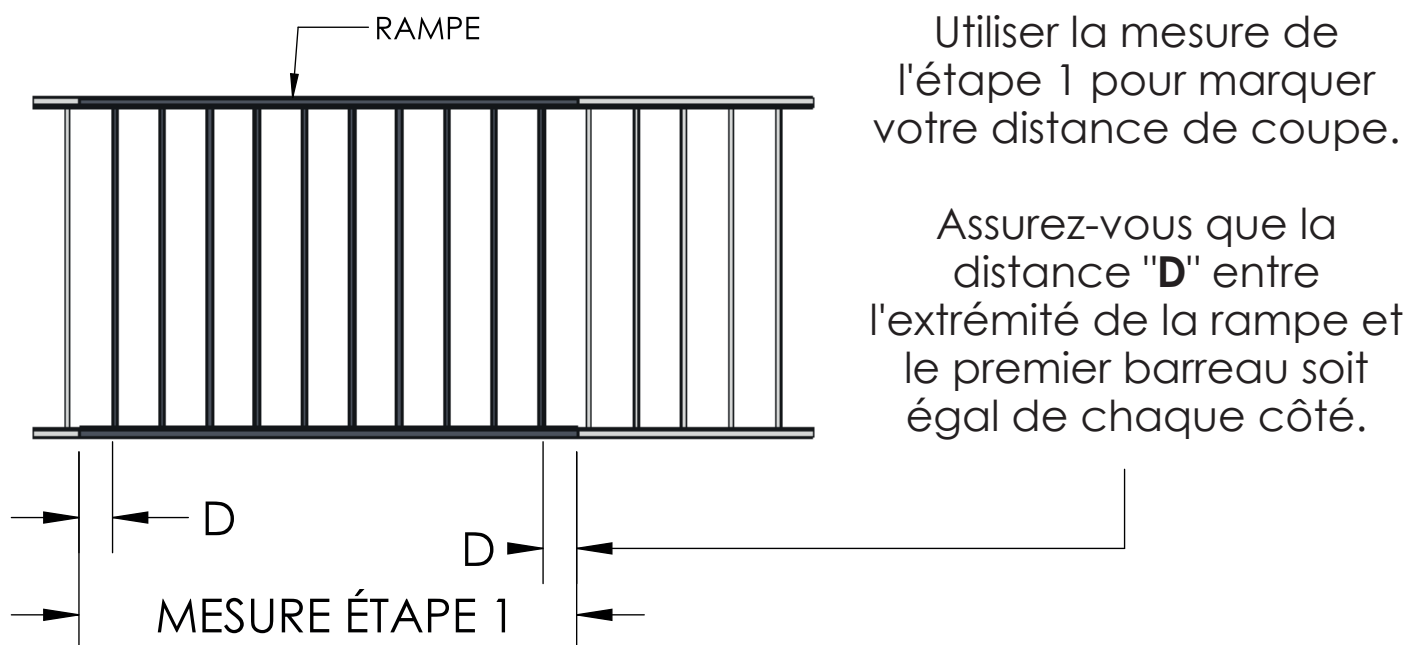

ÉTAPE 3

Couper les moulures de finitions 1/16" de moins que votre mesure "L" de l'étape 1. Cela a pour but de ne pas égratigner le poteau lors de l'installation

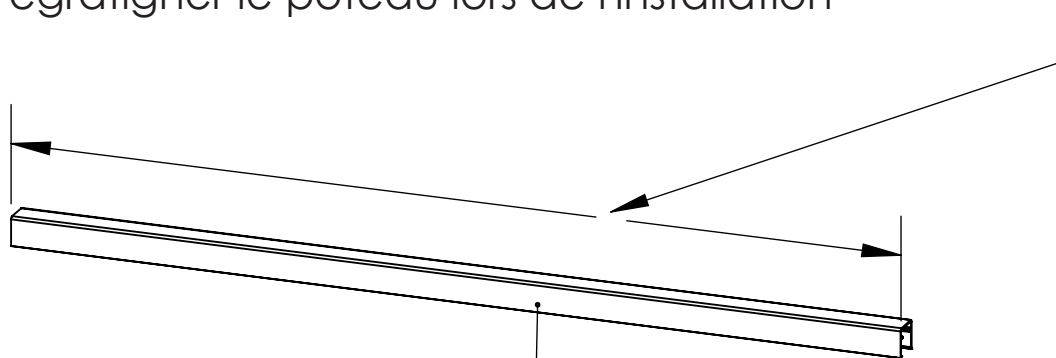

MOULURE DE FINITION DU HAUT
Ne pas percer

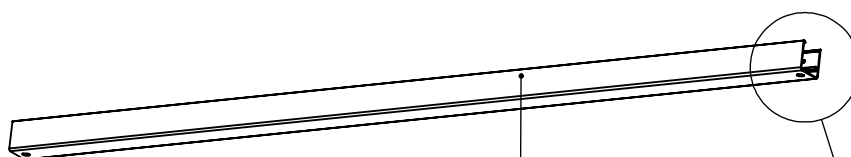

MOULURE DE FINITION DU BAS
*** Percer chaque côté***

Percer un trou 3/8" minimum à chaque extrémité de la moulure de finition du bas pour l'écoulement de l'eau

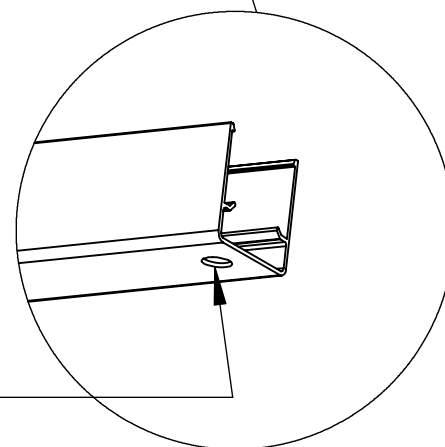

ÉTAPE 4

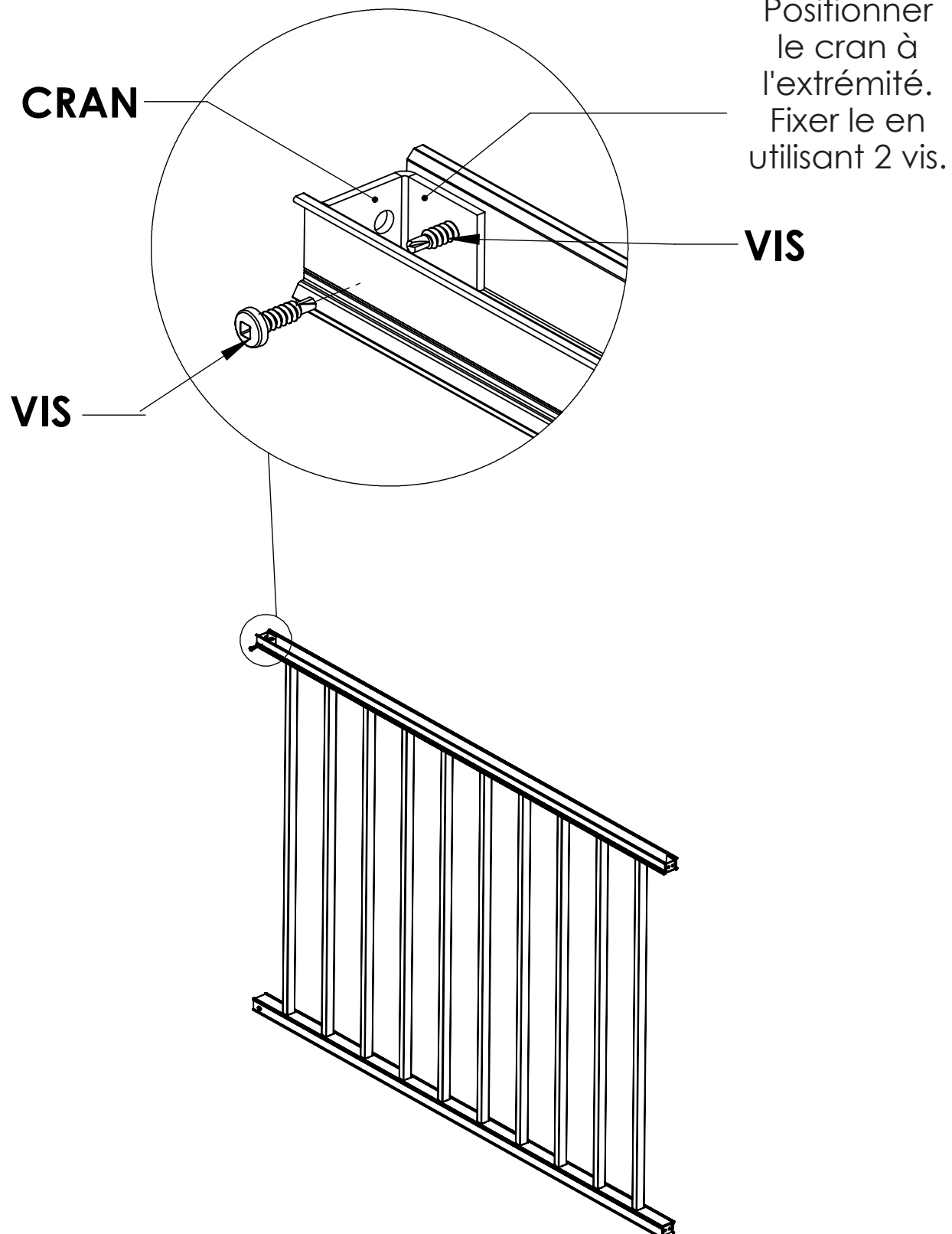

ÉTAPE 5

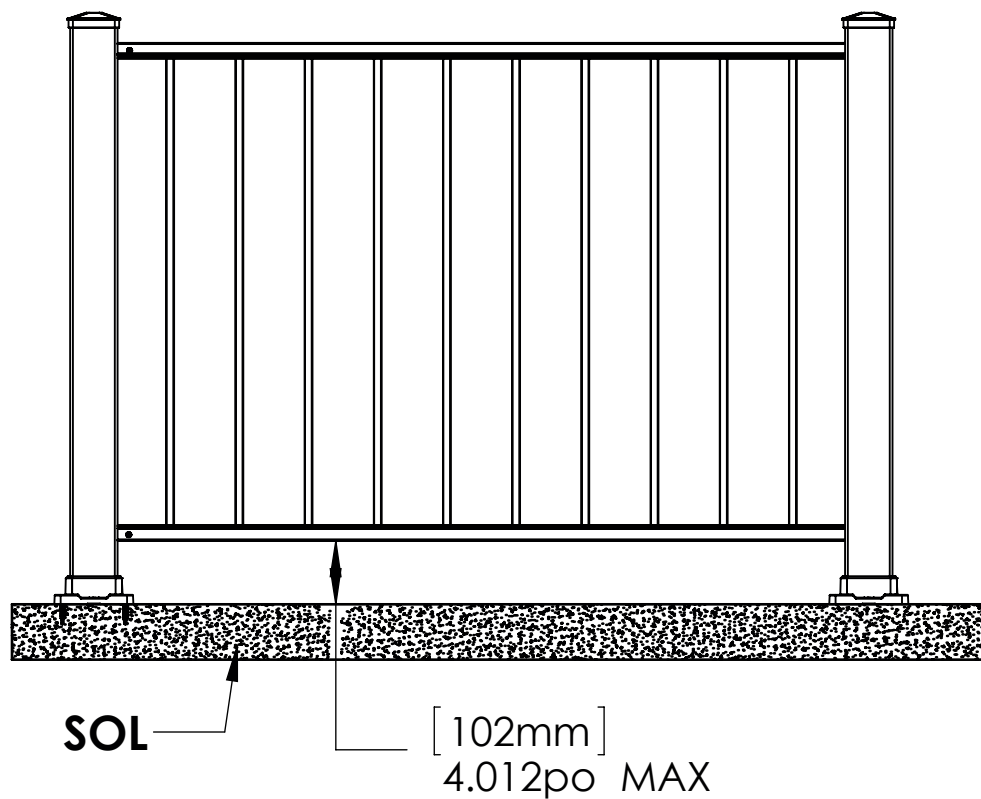
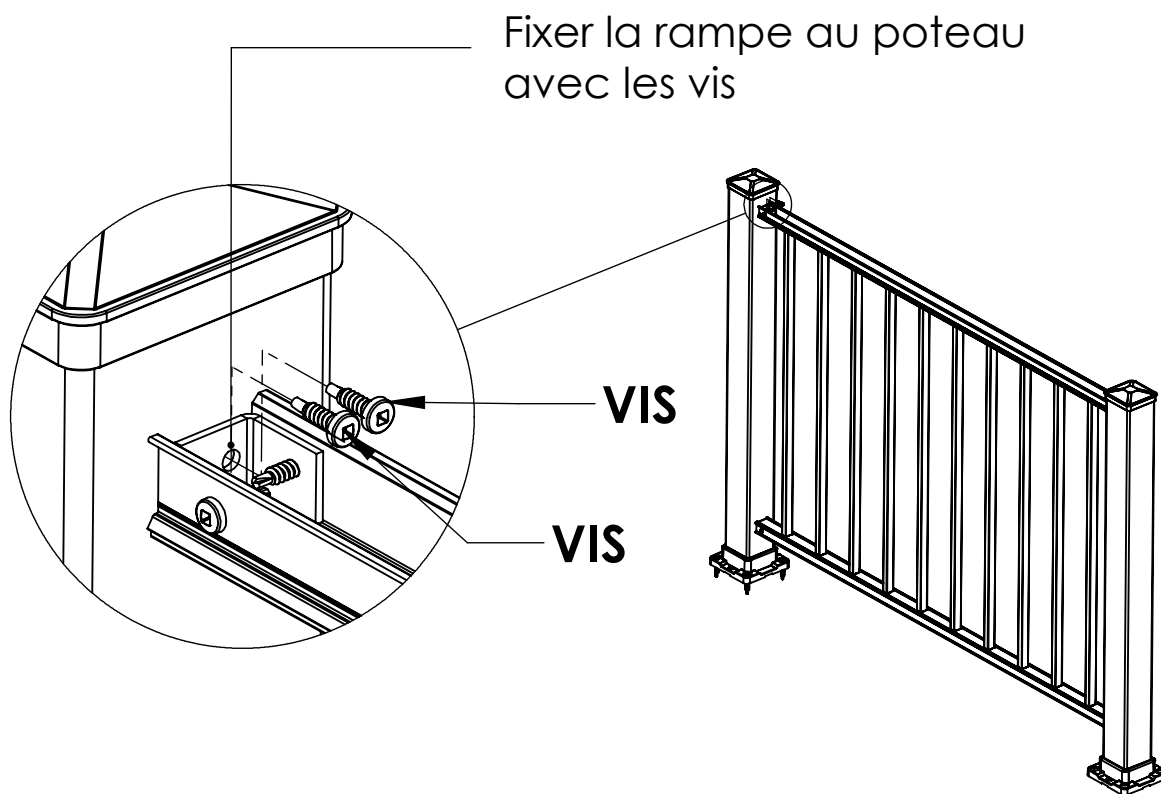

ÉTAPE 6

Insérer les moulures de finition sur le dessus et le bas de la section

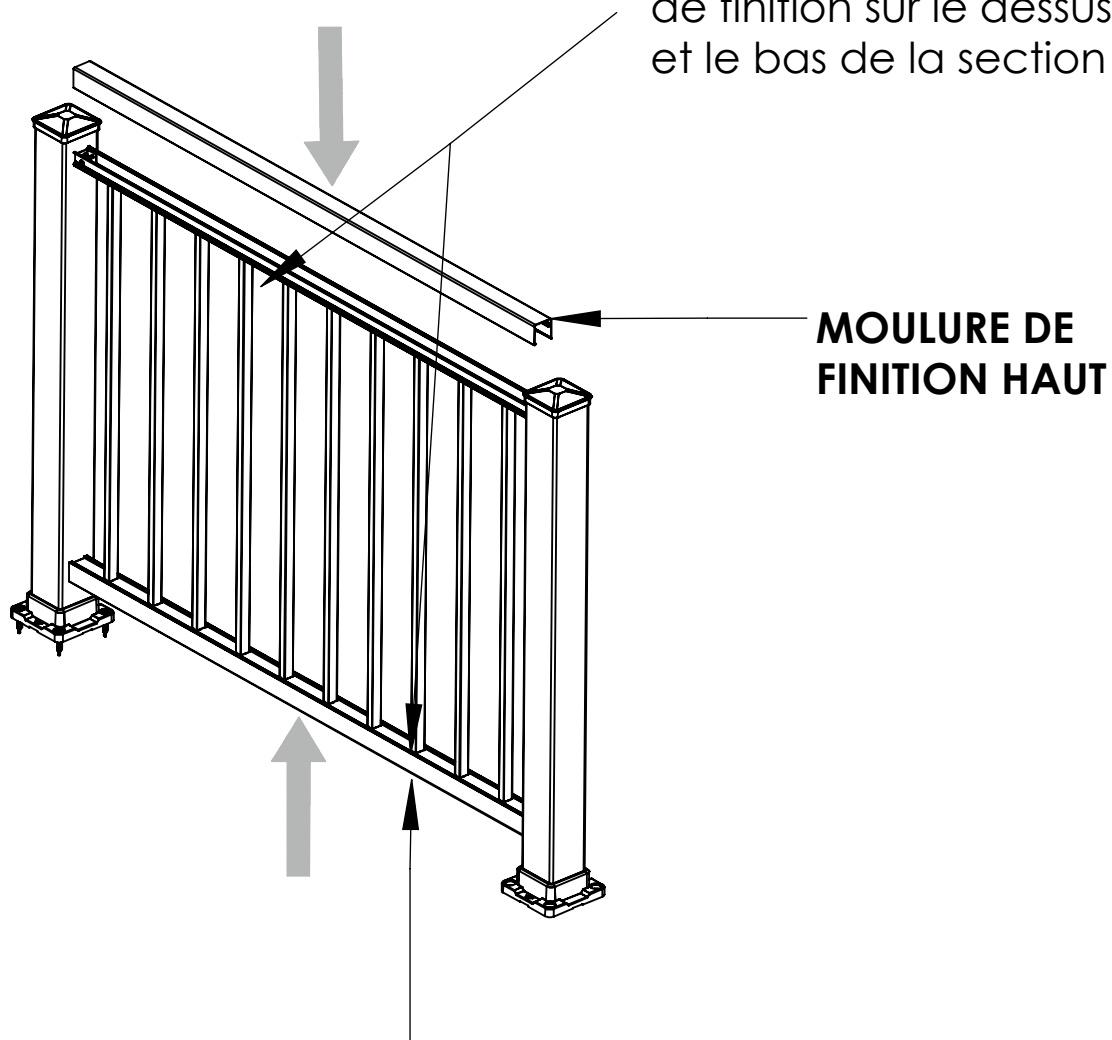

**MOULURE DE
FINITION HAUT**

MOULURE DE FINITION BAS
Perçer à l'étape 3